

Peak

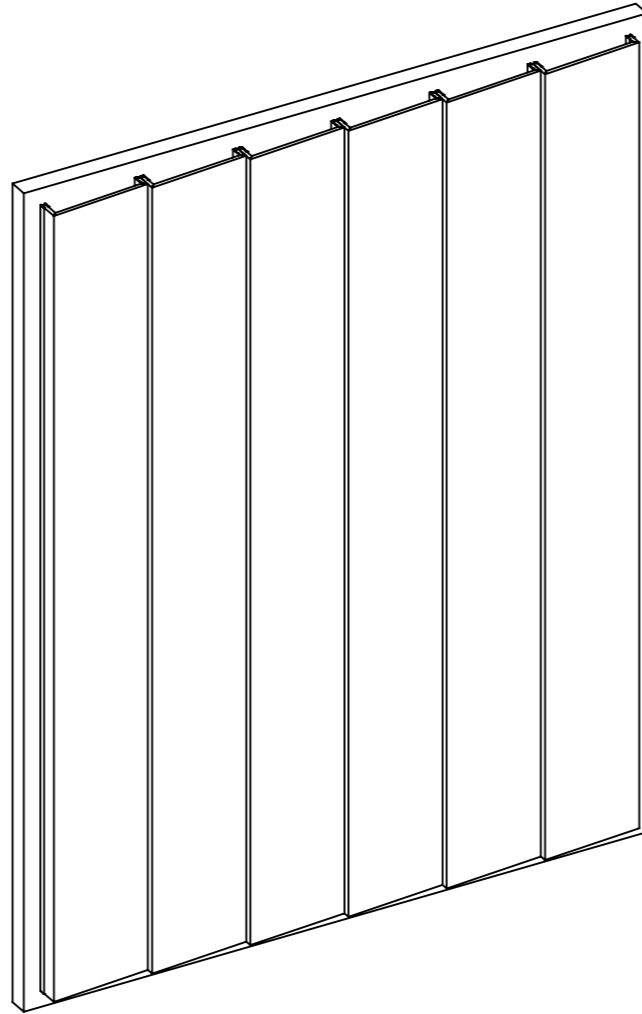

Sawtooth

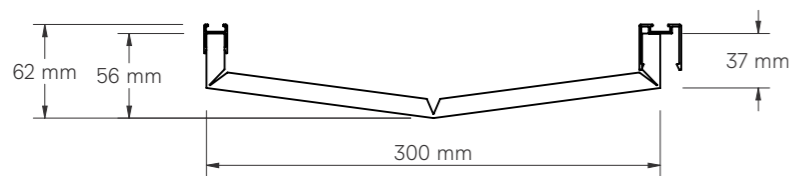
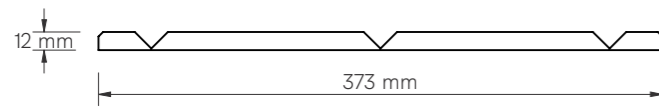
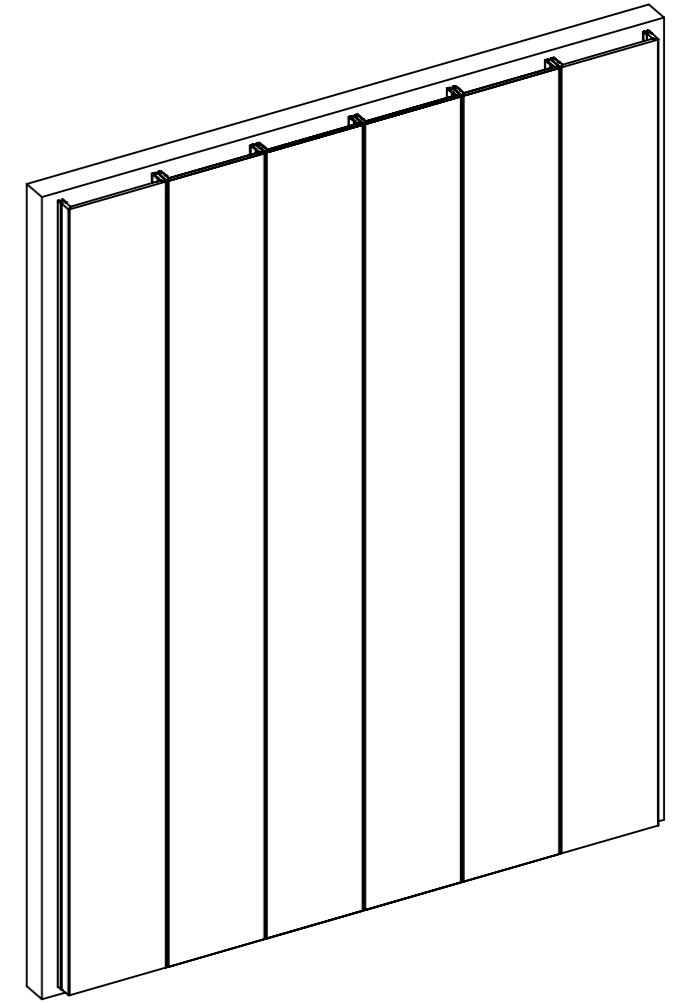
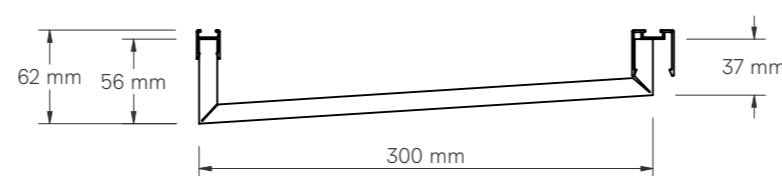
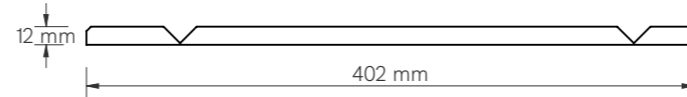

Plane

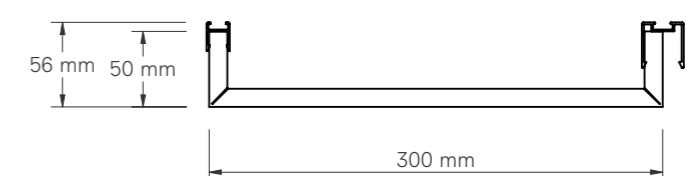
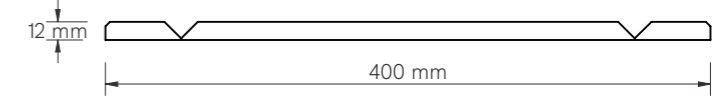

Note:
• Channels add 6mm to overall depth once installed

RAFLEX24PCB channels (24 mm)

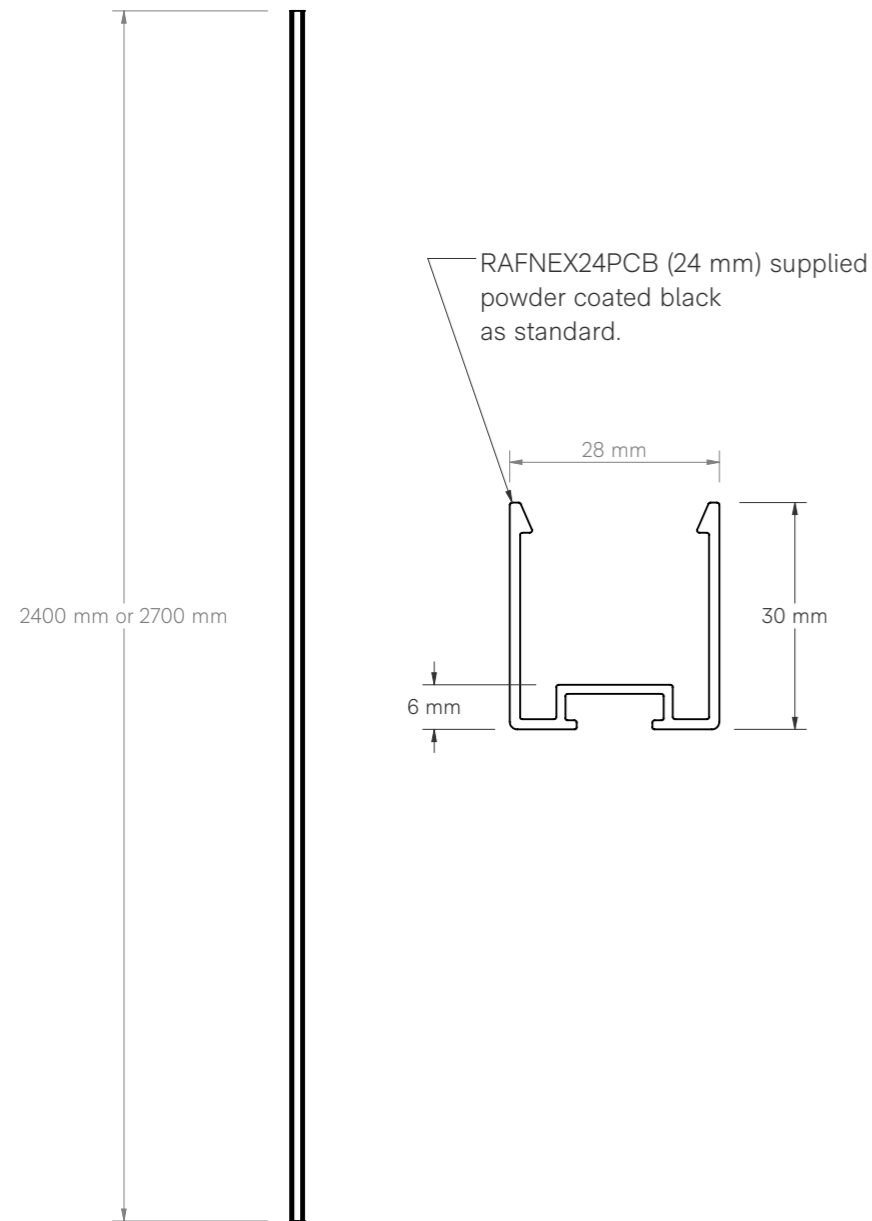

RAFLEXPCB channels (12 mm)

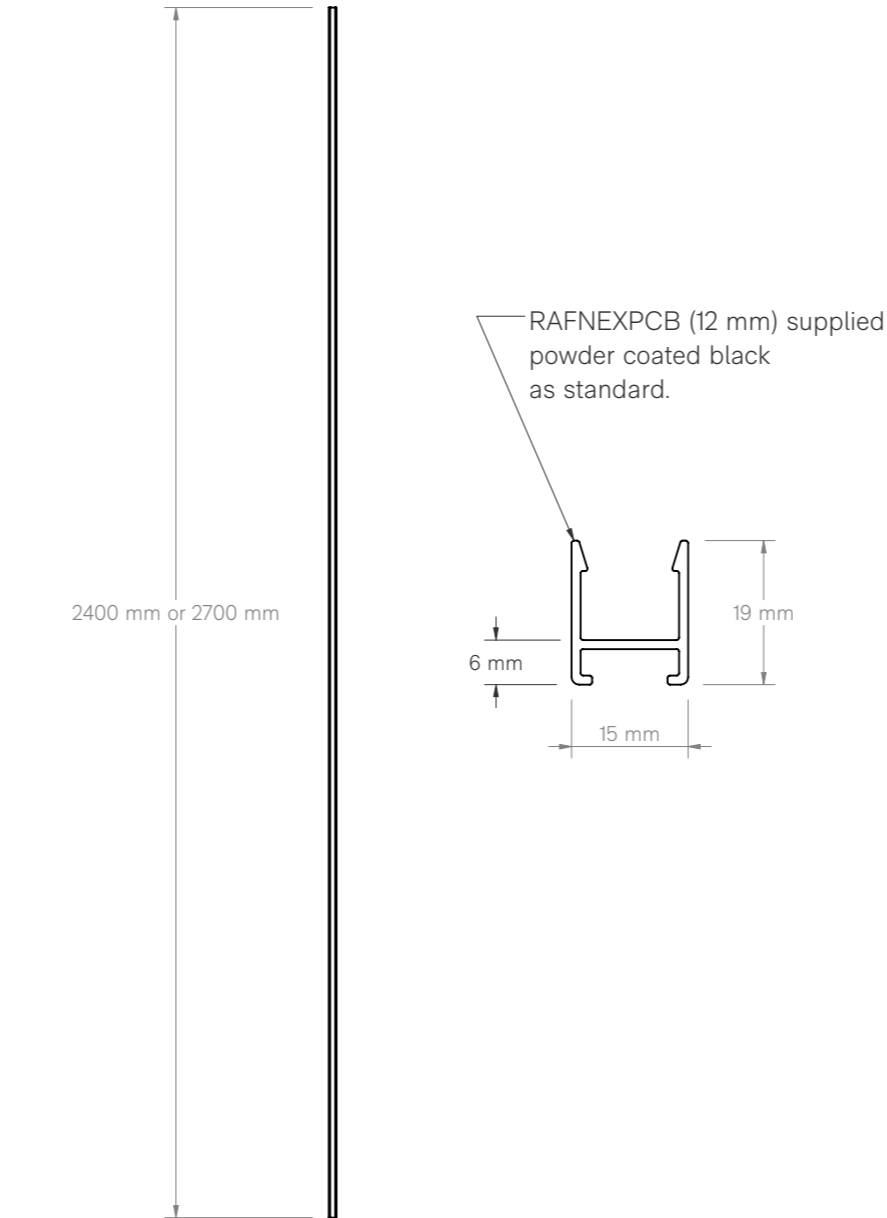

Channel quantities

At time of ordering, specify the required extrusion types and quantities to complete the installation.

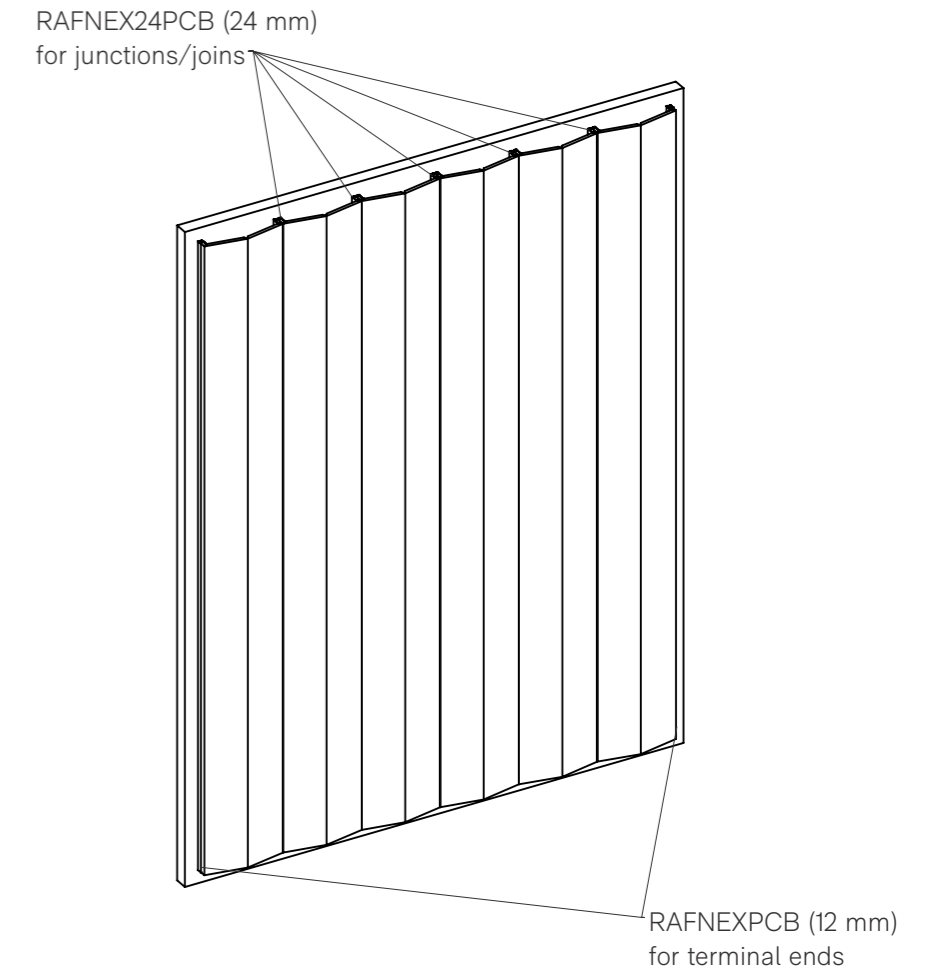

This example would require the following extrusion types and quantities:

- 2 x RAFLEXPCB (12 mm)
- 5 x RAFLEX24PCB (24 mm)
- 6 x Lanes profiles in selected style and finish

Note:

Channels are supplied as standard in powder coated matt black. If other colours are required, please confirm at time of ordering. Additional charges and lead time may apply.

Note:

- Custom lengths available up to 3600 mm (please specify when ordering if required, MOQs apply)
- Confirm quantity needed at the time of ordering (refer to the diagram on the right of this page)
- Appropriate fixings for wall substrate are not provided by Autex Acoustics

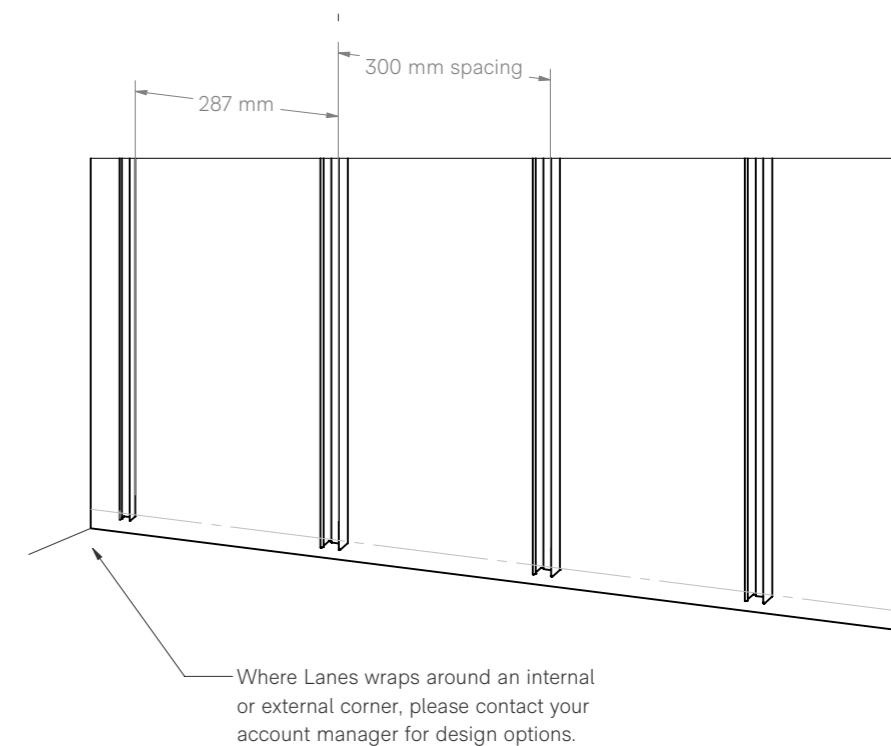
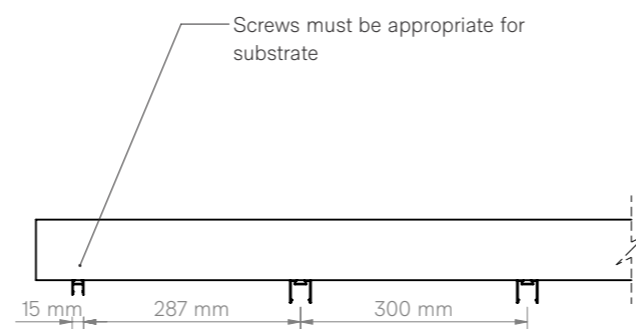
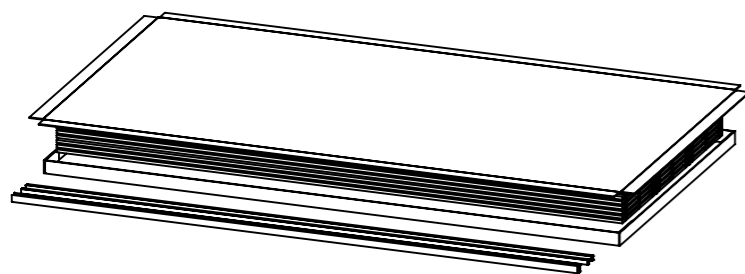

Site preparation:

- Confirm substrate is suitable to safely secure Autex Lanes to.
- Seal all gaps and cracks on the substrate before starting installation.
- Check package of contents that the correct number of profiles have been supplied. Specified Lanes profiles will be packaged in number divisible by three.

Measure install area:

- Confirm the required locations and layout for fixing points prior to commencing installation.
- Measure and mark all fixing points in the install area(s).
- The centre of first 24 mm channel will be 287 mm from the internal edge of the 12 mm channel. Subsequent channels will be spaced at 300 mm centres from there on.
- Install tip: mark a line on the wall to show the inside edge of the first 12 mm channel. This will make the line easier to locate when screwing the channel to the wall.

Fix channels to substrate:

- Secure each extrusion with a suitable fixing (not supplied by Autex Acoustics). Countersunk screws are best to ensure Lanes product fits properly into the channel.
- Place channel fixings within 100 mm from each channel end, and at intervals not exceeding 600 mm along the channel.
- Ideally, attach fixings through to the frame behind. Otherwise if needed, use suitable anchors, such as plasterboard anchors.
- The installer is responsible for choosing the appropriate fixing for the specific substrate.

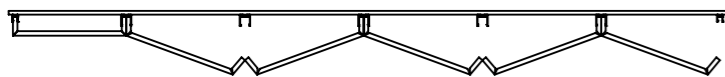

Insert Lanes into channels:

- Fitting Lanes into channels is more easily undertaken with two people.
- Push the side edge of the first Lane into the 12 mm channel, ensuring a snug fit along the entire channel length.
- Fit the other edge of the folded panel into the next 24 mm channel, along with the next Lanes panel. Repeat for the remaining sections.
- Install tip: Pre-fold each Lanes panel to reduce tension while installing. When fitting into channels, start at either the bottom or top and work both layers into the extrusion, making sure they fit snugly along the entire channel length.

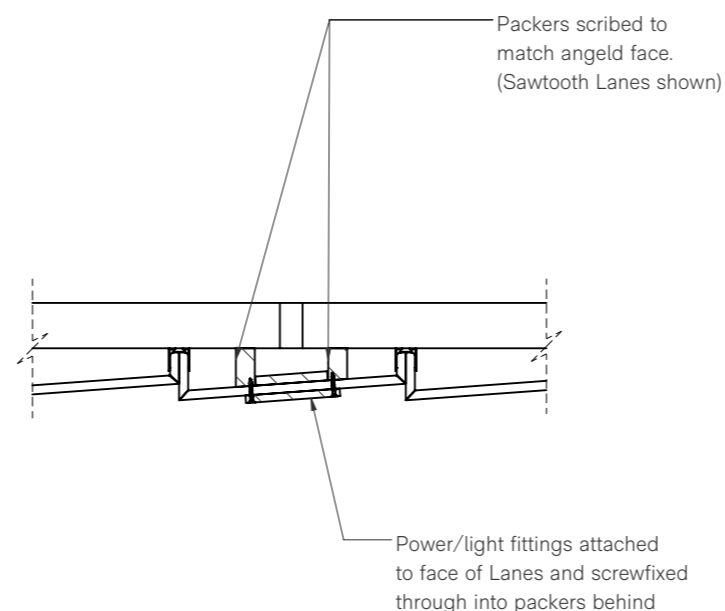

Fixtures and fittings:

- Where Lanes cover electrical fittings including switches, lighting, GPOs and other devices these must be secured back to the substrate using packers or blocks.
- Remove cover plates, light fittings, fire safety devices and make safe prior to installation. Face plates should completely cover any penetration made in facing to ensure a professional finish.
- **IMPORTANT:** only approved individuals should remove and reinstall any fittings related to electrical, gas, or other safety systems in compliance with local laws.
- When dealing with angled profiles, custom-fit packers to match the angle. Seal all holes and gaps with an appropriate sealer to stop the ingress of dust and other airborne particles.
- Lanes can be trimmed to length on-site if required. Use appropriate tools to neatly and safely trim the aluminium extrusions. For Cube components, use a straight edge and a sharp utility knife for a clean, tidy finish.



Disclaimer:

Lanes should be installed in accordance with these Install Instructions and as per the specification detail and customer requirements. If there is conflicting information, you must seek clarification from all appropriate parties before proceeding with the work. It is imperative that the installation is planned before cutting any product.